

DETAIL K
HYD OIL COOLER SWITCHES
(VIEW LOOKING UP AT RETURN MANIFOLD)

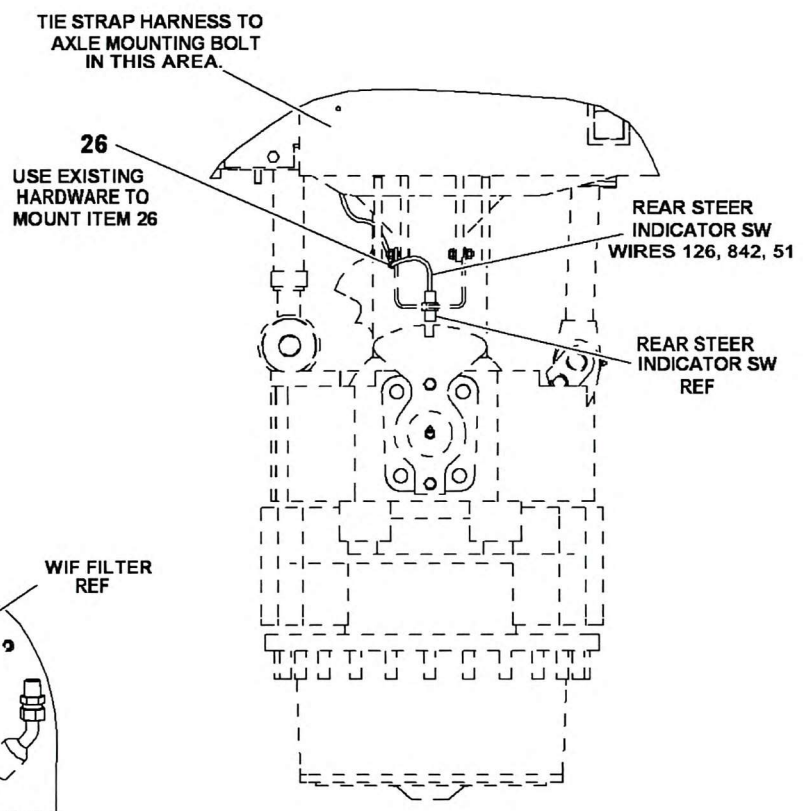

DETAIL J
REAR STEER INDICATOR (LEFT REAR WHEEL)
(AXLE LOCKOUT CYLINDER NOT SHOWN FOR CLARITY)

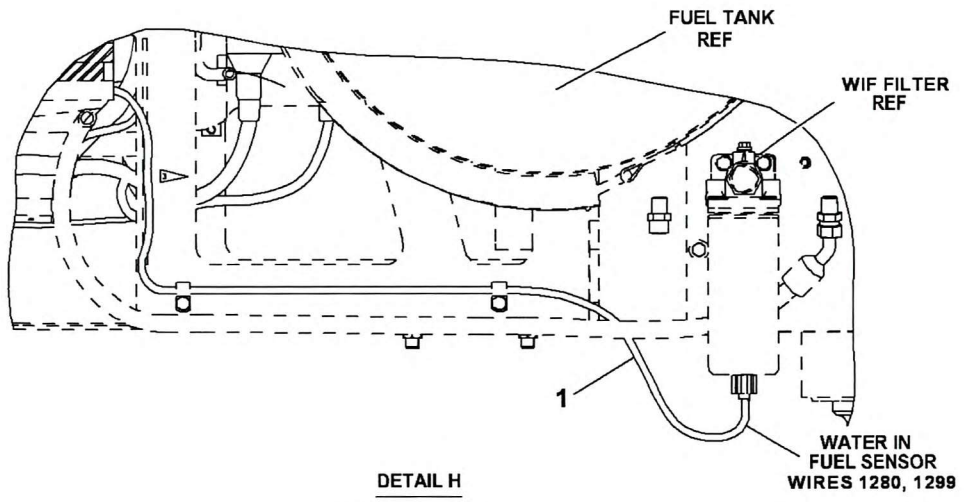

DETAIL H
WATER IN FUEL SENSOR CONNECTION

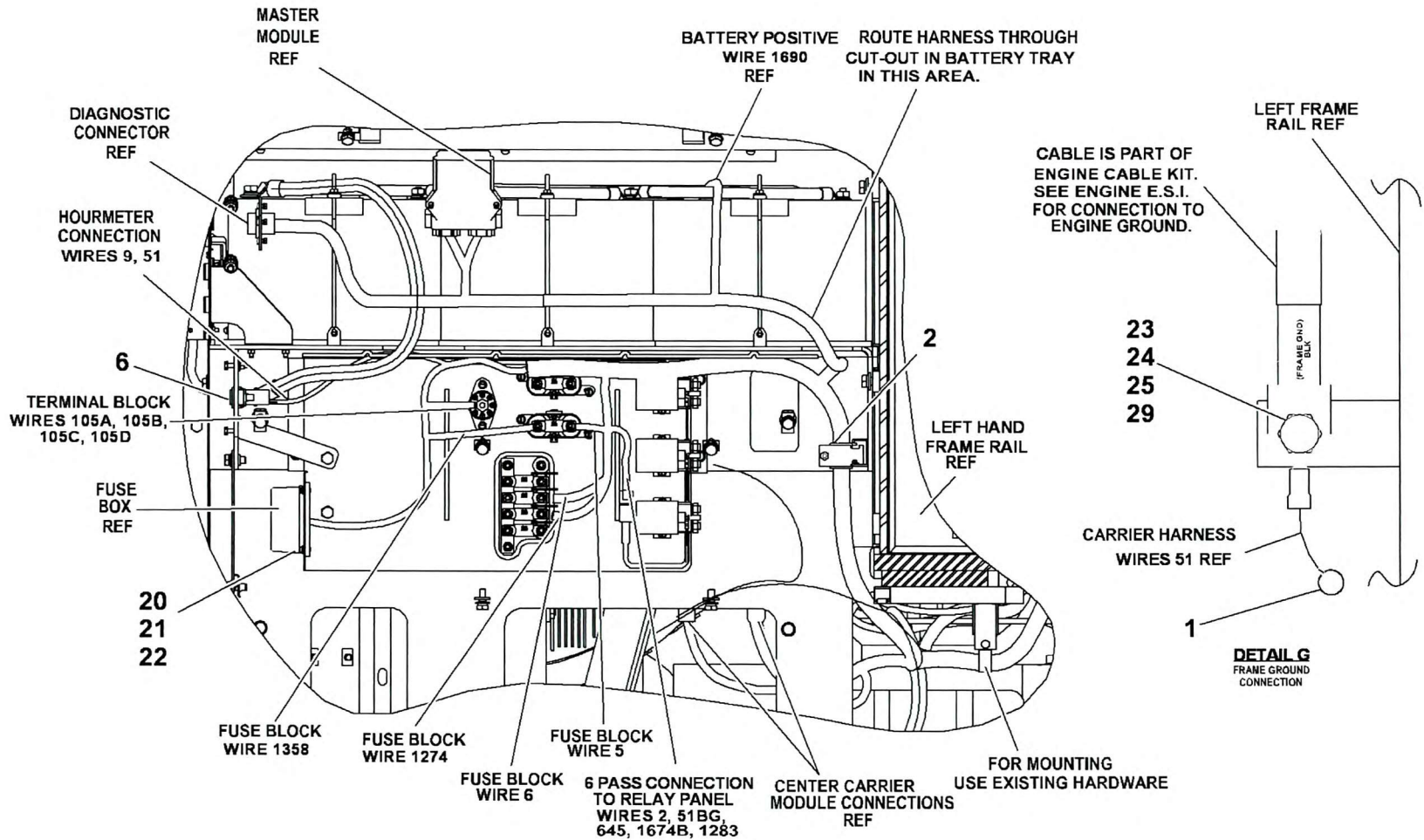

SECTION H-H

TERMINAL BLOCK, RELAY,
HOURMETER, AND FUSE BLOCK
CONNECTIONS
(PANEL WIRES NOT SHOWN FOR CLARITY)

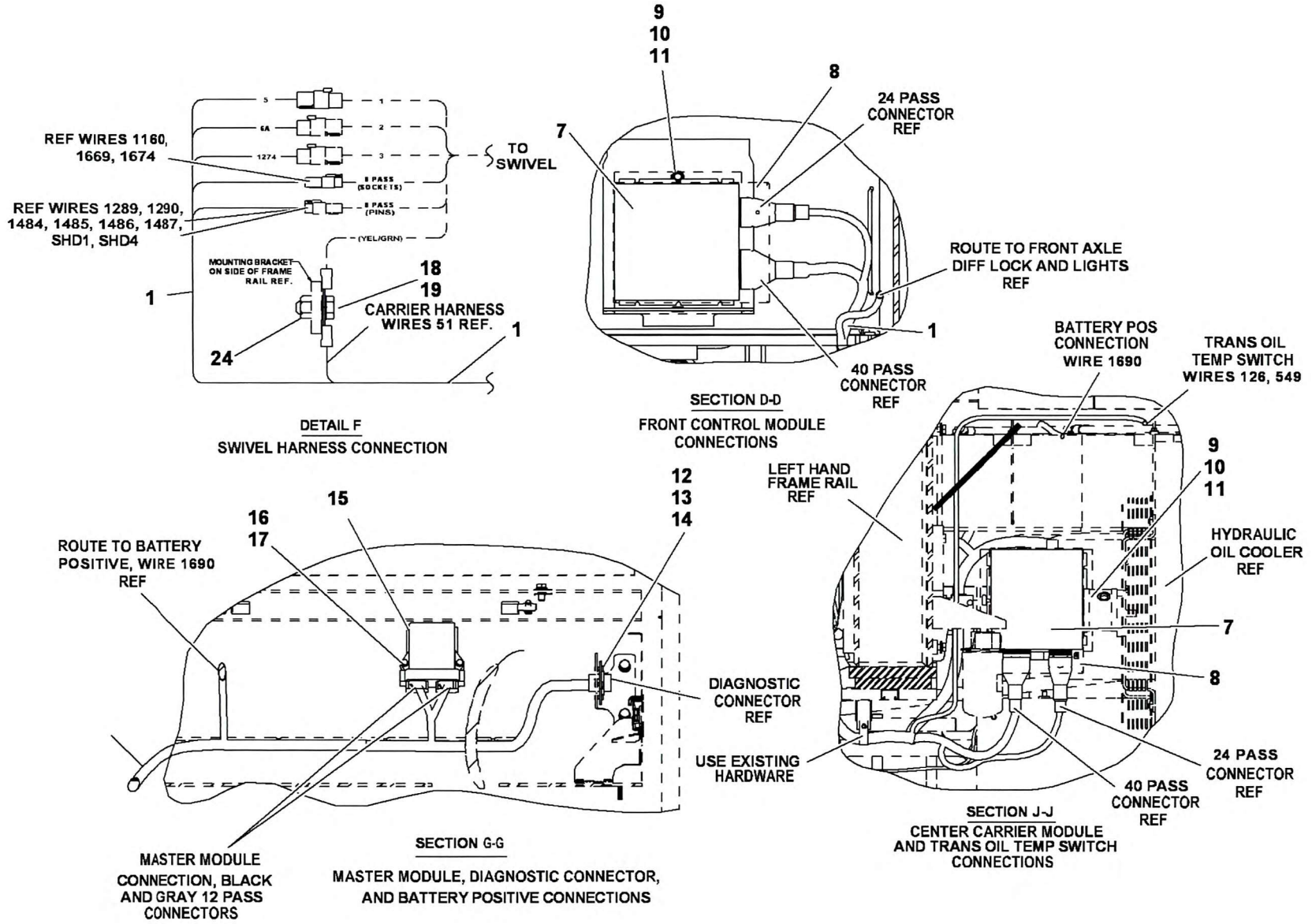

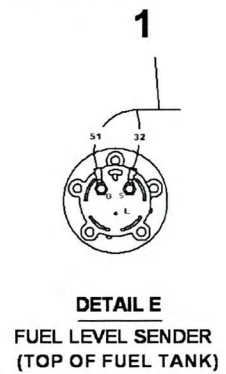
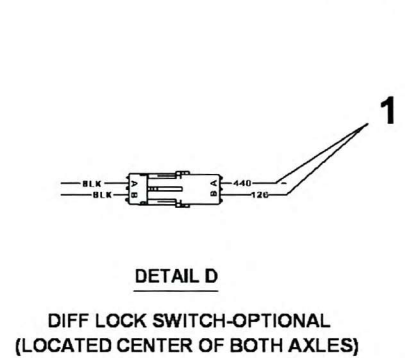
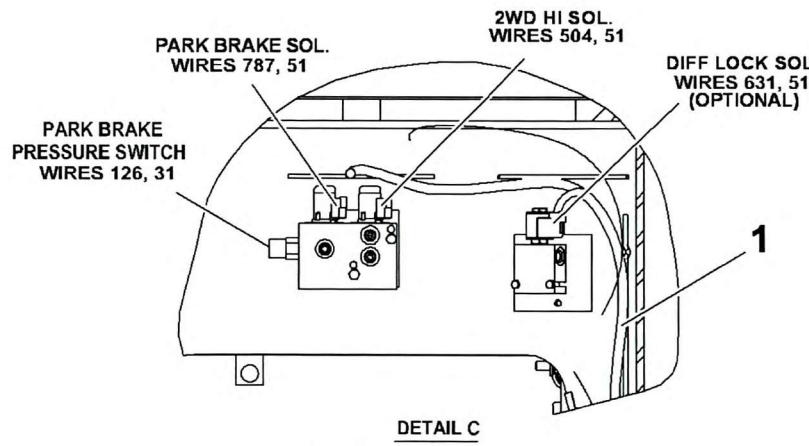
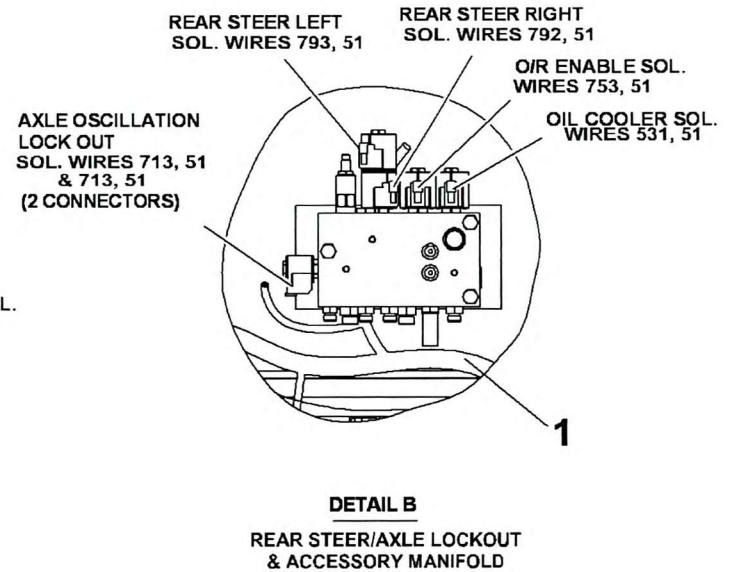
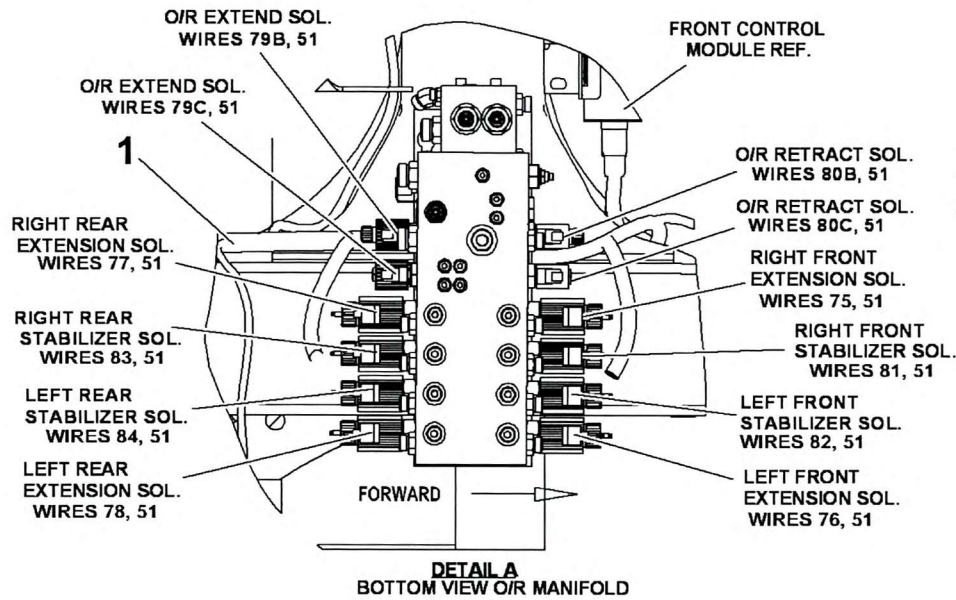

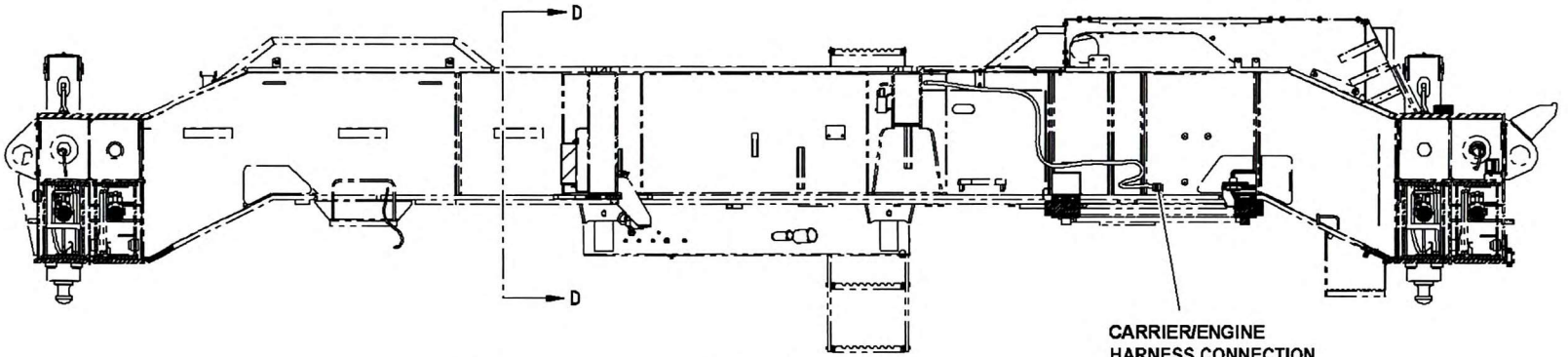

SECTION A-A
(AXLES NOT SHOWN FOR CLARITY)

CARRIER/ENGINE
HARNESS CONNECTION

PUMP LOAD
SENSE SOLENOID
WIRES 2, 51

SEE DETAIL G
FRAME GROUND
(SHT 05)

SEE DETAIL F
SWIVEL HARNESS
CONNECTION
(SHT 04)

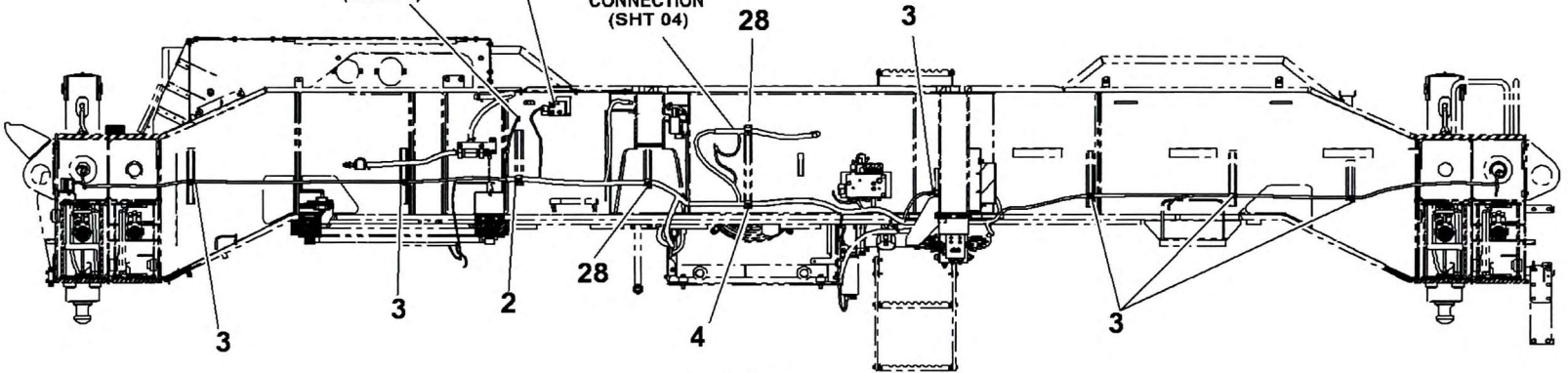

SECTION B-B
(AXLES NOT SHOWN FOR CLARITY)

